

### Fuel Gas Pressure Piping in Plants

This bulletin has been jointly developed by Safety Services, the Pressure Equipment Sub-Council, the Alberta Boilers Safety Association (ABSA) and the Gas Sub-Council to inform industry of the requirements associated with the installation of fuel gas pressure piping in Alberta.

The purpose of this Information Bulletin is to ensure that **Designers** and **Installers** are aware of the provisions for fuel gas service pressure piping above and below **15 psi (103 kPa)** and of the necessary engagement with the authorities having jurisdiction before designs are finalized and the work proceeds.

This STANDATA establishes the specification break points between the *Gas Code Regulation (AR 111/2010)* and the *Pressure Equipment Safety Regulation (AR 49/2006)* for piping in fuel gas service installed at Plants with and without **Owner-user** programs:

- Fuel gas piping for pressure not exceeding 15 psi (103 kPa) and piping at all pressures located in between the appliance shut-off valve and the burner shall be designed and constructed in accordance with the *Gas Code Regulation*.
- Process gas piping for pressure exceeding 15 psi (103 kPa) shall be designed and constructed as “pressure piping” in accordance with the *Pressure Equipment Safety Regulation*.
- Fuel gas piping for pressure exceeding 15 psi (103 kPa) located upstream of the appliance shut-off valve at **Owner-user** facilities shall be designed and constructed as “pressure piping” in accordance with the *Pressure Equipment Safety Regulation*.

All fuel gas piping systems shall be permitted and shall meet the requirements of the Gas Code Regulation, except for the portion of the piping that is approved as part of the pressure piping at an Owner-user facility.

The CSA B149.1 - *Natural Gas and Propane Installation Code* addresses all piping systems that convey fuel gas to fuel burning appliances, at all pressure levels.

*The Pressure Equipment Safety Regulation* under the *Safety Codes Act* adopts certain *ASME B31 Piping Codes* and the *CSA B51 Boiler, pressure vessel, and pressure piping code*. The *Pressure Equipment Safety Regulation* addresses “pressure piping” (as defined below). Gas piping used exclusively for fuel purposes regulated under the *Gas Code Regulation* is specifically exempt from the *Pressure Equipment Safety Regulation*.



Issue of this STANDATA is authorized by  
the Chief Gas Administrator and  
the Chief Boilers and Pressure Vessels Administrator



The *Pressure Equipment Safety Regulation* does not apply to:

- (a) a pressure piping system operating at and with relief valves set at 103 kPa (15 psig) or less;
- (b) piping systems used to convey gas exclusively for fuel purposes and that is subject to the Gas Code Regulation.

Administration of the *Pressure Equipment Safety Regulation* has been delegated to ABSA. In the *Pressure Equipment Safety Regulation*, the following definitions apply to the design and construction of a pressure piping system:

**"Pressure Piping System"** means pipe, tubes, conduits, fittings, gaskets, bolting and other components that make up a system for the conveyance of an expansible fluid under pressure and may also control the flow of that fluid.

**"Expansible Fluid"** means

- (i) a vapour or gaseous fluid, or
- (ii) a liquid under pressure and at a temperature at which the liquid changes to a gas or vapour when the pressure is reduced to atmospheric pressure or when the temperature is increased to ambient temperature.

In this document the term

**"Owner-user"** means an owner of pressure equipment that has provided an Integrity Management System in accordance with the *Pressure Equipment Safety Regulation* and has been issued a quality management system Certificate of Authorization Permit under PESR section 11(3).

**"Fuel Gas"** means any of the following gases or mixtures of gases utilized within the scope of the CSA B149.1 and may include natural gas, manufactured gas, or mixtures of propane gas and air, propane, propylene, butanes (normal butane or isobutane), and butylene. And includes manufactured gas such as hydrogen, raw gas, well head gas, process generated gas and may include sweet, sour or wet applications.

The *Gas Code Regulation* adopted the CSA-B149.1. This code applies to the installation of piping and tubing systems, appliances, equipment, components, venting and accessories where **gas** is to be used for **fuel purposes**, but does not cover piping or tubing where the gas is used as feedstock or process gas.

Installations of fuel gas using manufactured gas (as defined above) shall meet the intent of the Gas Code Regulation by utilizing appliances that are certified or approved as indicated under the options within the Gas Code Regulation and through the Province-wide variance Var-Gas-01-13[Rev2]. Hydrogen gas as a fuel is currently addressed as an extension of a CSA B149.1 permitted installation that would address the installation of the piping. Such installations may be considered for compliance under complex project provisions requiring the engineer of record to integrate the CAN/BNQ 1784-000 Canadian hydrogen code into the design package.

### Permitting requirements under both Gas & Pressure Equipment Disciplines

The *Permit Regulation AR 204/2007*, under the *Safety Codes Act*, indicates that a permit, for a gas installation that is under the gas discipline, is required:

“12(1) A permit in the gas discipline is required to install, alter or add to a gas system.”

Work performed on piping under the jurisdiction of the *Gas Code Regulation (AR 111/2010)* must be done by certified gas fitters.

Work performed under the jurisdiction of the *Pressure Equipment Safety Regulation* shall follow the requirements outlined therein and in accordance with ABSA document AB-518.

### **Gas piping systems at owner-user plant sites.**

1. Gas piping systems installed at owner-user facilities having a design pressure in excess of 15 psi (103 kPa) shall be deemed pressure piping and subject to the *Pressure Equipment Safety Regulation* and shall be included in the design registration of the pressure piping system for the facility.
2. The construction, modification, repair or alteration of a gas piping system referenced in point 1 above shall be performed by the holder of a quality management system certificate of authorization permit and in full compliance with the *Pressure Equipment Safety Regulation*.
3. The construction inspection of the gas piping upstream of the appliance isolation valve and/or the pressure regulator (where the pressure is reduced to 103 kPa or less) shall be carried out by an owner's inspector in accordance with the code of construction and documented on an ABSA form AB-83 *Piping Construction and Test Data Report*.
4. The installation inspection of the piping system appliance isolation valve and/or pressure regulator will be carried out by a gas safety codes officer under the *Gas Code Regulation*. The required gas permit will also cover the installation of the gas-fired appliance and the final piping where gas is used for fuel purposes.

Installation inspection carried out under *Gas Code Regulation (AR 111/2010)* shall include:

- Verification from the owner or contractor that the upstream pressure piping system has been registered with ABSA;
- Verification the AB-83 form has been completed and signed off by the owner's inspector.
- Installer qualifications (gasfitter) respecting the type of installation permitted;
- Piping and tubing systems (verifying size, schedule, capacity, supports, etc.);
- Pressure regulators and line relief devices (verifying working pressures, capacities, venting to a safe location outdoors);
- Appliances (verifying certification, approvals for Alberta, clearances, protection, venting systems and air supply);
- For underground piping and tubing (verifying burial depth, routings away from buildings, sleeves on riser passing through concrete/pavement, use of swing joint on entry to buildings, etc.)
- Odorization as required in CSA Z662 (when gas is utilized for fuel purposes); and
- Other inspection items associated with CSA B149 Codes and referenced standards.

### **Fuel gas piping systems at all other plant sites not managed by an Owner-user.**

1. Fuel gas piping systems installed at all design pressures shall be deemed fuel gas piping and subject to the *Gas Code Regulation*.
2. The construction, modification, repair or alteration of a fuel gas piping system reference in point 1 above shall be performed by a holder of an appropriate trade certificate of competency and in full compliance with the trade regulations under *Alberta Innovation and Advanced Education / Apprenticeship and Industry Training (AIT)*.

3. The installation inspection of the piping system including appliances, isolation valve and/or pressure regulator, and piping from the isolation valve and/or regulator to the burner will be carried out by a gas safety codes officer under the *Gas Code Regulation*. The required gas permit will cover the installation of the gas-fired appliance and the final piping where gas is used for fuel purposes.

Installation inspection carried out under *Gas Code Regulation (AR 111/2010)* and shall include:

- Verification from the owner or contractor that the pressure piping system (if applicable) has been registered with ABSA;
- Installer qualifications (gasfitter) respecting the type of installation permitted;
- Piping and tubing systems (size, schedule, capacity, supports, etc.);
- Pressure regulators and line relief devices (working pressures, capacities, venting to a safe location outdoors);
- Appliances (certification, approvals for Alberta, clearances, protection, venting systems and air supply);
- For underground piping and tubing (burial depth, not permitted under building, sleeves on riser passing through concrete/pavement, swing joint on entry to buildings, etc.);
- Odorization or equivalent (when process gas is utilized for fuel purposes); and
- Other inspection items associated with CSA B149 Codes and referenced standards

A natural gas service and meter upstream of a gas distribution system on a plant site shall be in accordance with the *Pipeline Act*, or the *Oil and Gas Conservation Act* as appropriate including regulations and referenced codes/standards.

Anyone concerned about the status of a fuel gas piping system or a pressure piping system could contact Alberta Municipal Affairs, Safety Services office, visit the Web site, [www.municipalaffairs.alberta.ca/cp\\_index.cfm](http://www.municipalaffairs.alberta.ca/cp_index.cfm), contact the local ABSA office or visit ABSA Web site, <http://www.absa.ca> for further information.

[Original Signed] \_\_\_\_\_

Mike Poehlmann  
Administrator and Chief Inspector  
Pressure Equipment Safety (ABSA)

[Original Signed] \_\_\_\_\_

Sidney Manning  
Chief Administrator/Inspector  
Plumbing and Gas (AMA)

- Gas Supplier Distribution line  (Alberta Resource Development, Rural Utilities Branch)
- Process Distribution  ABSA – Registered Pressure piping system
- Fuel Distribution  Gas Safety / ABSA Registered as process gas for Owner-User if pressure >15psi
- Appliance (Certified / Uncertified)  Gas Code Regulation

## Plant Site

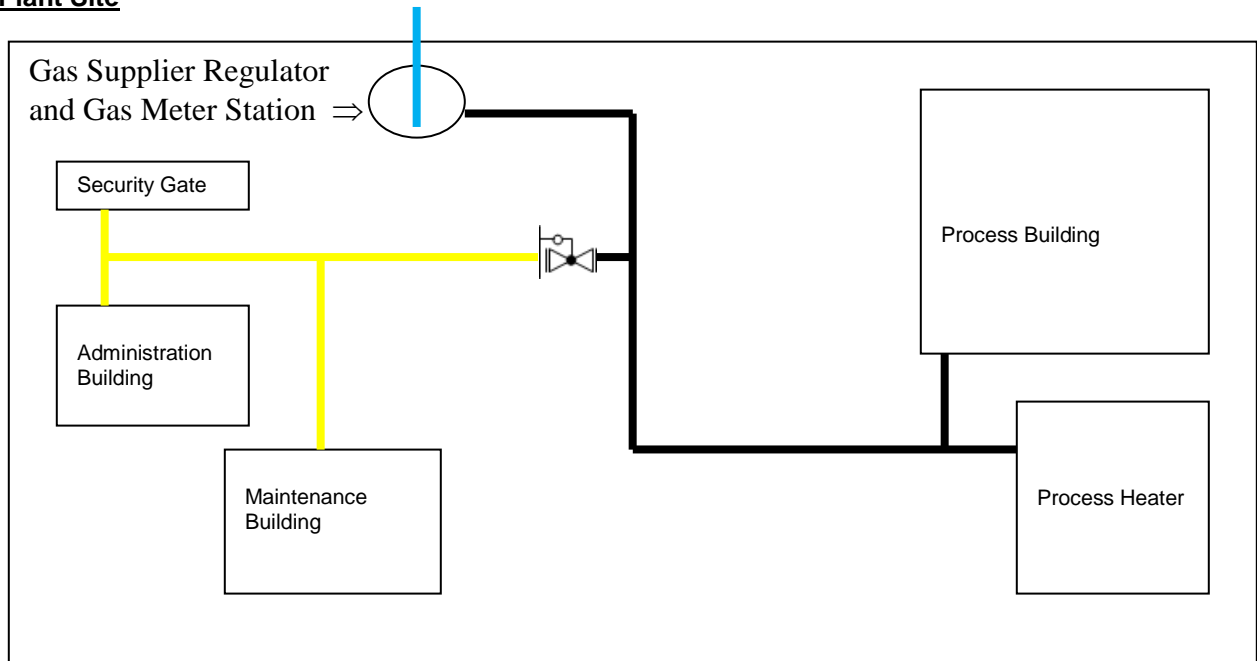

## Process Building

**MUAH** – Roof top Make-up Air Units    **B** – Boiler (Space Heating)    **UH** – Unit Heater    **HWT** – Hot Water Tank

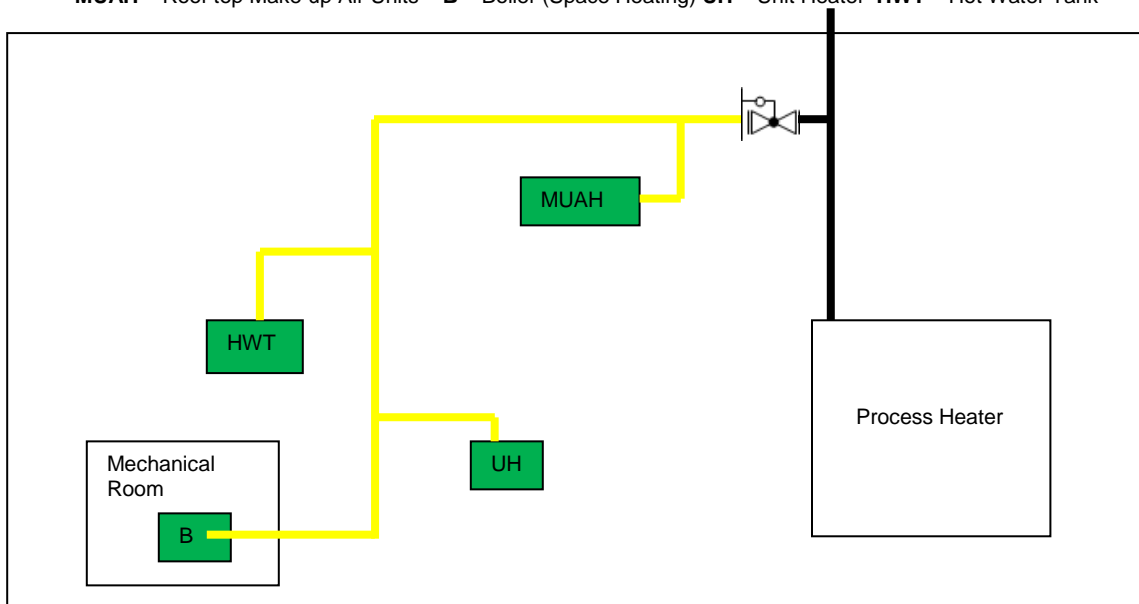

**Process Equipment**

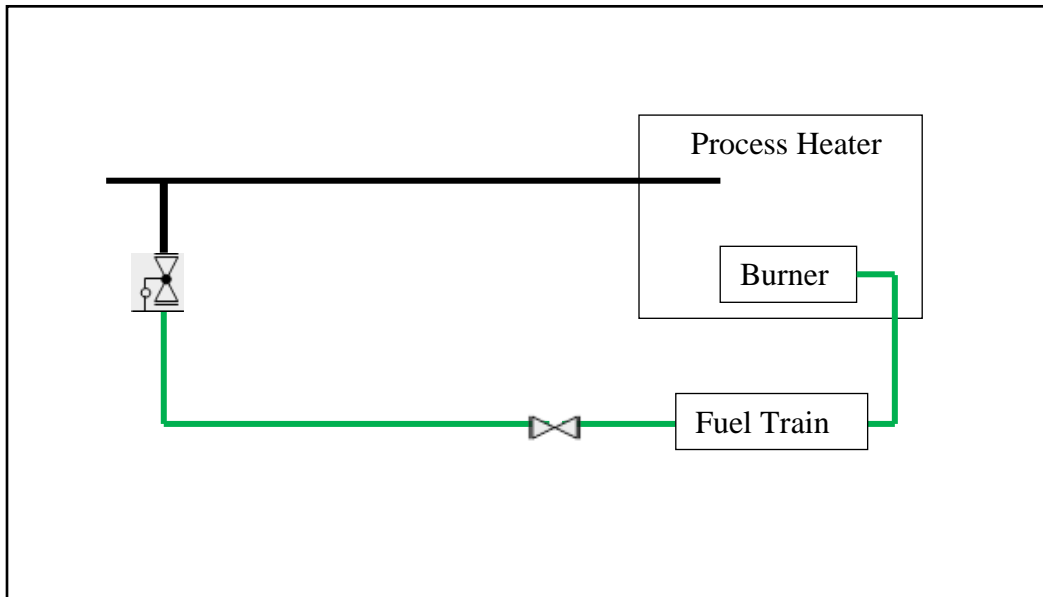

**Process Equipment Owner-User Over 15 PSI**

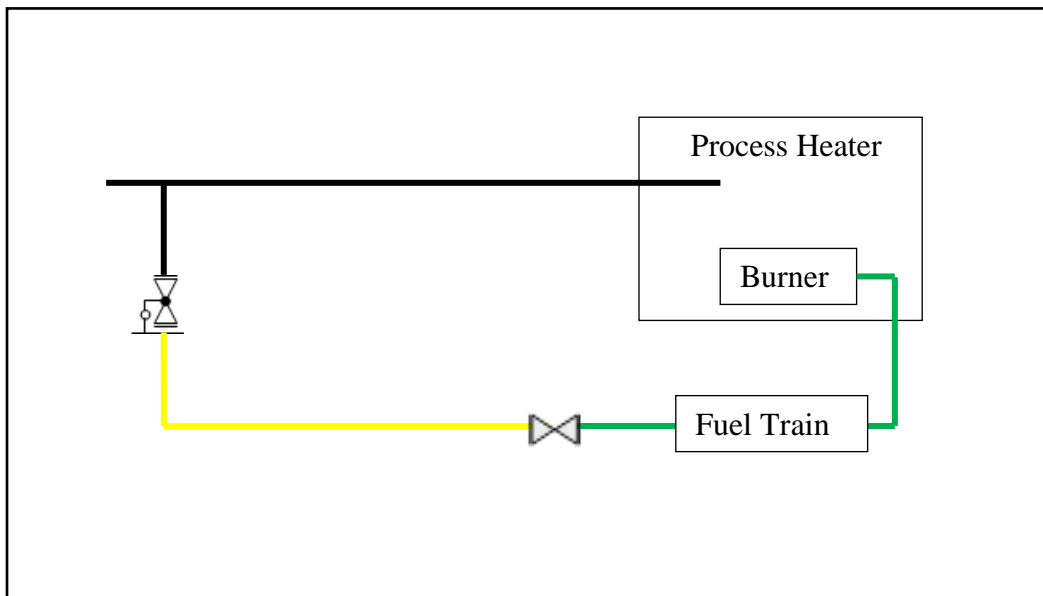

Process Heater

